

MDF MULTIPOINT DUCT FLOWPROBE

Ideal for average air volume measurement
Multiple differential pressure sensing points
Averaging impact pressure measurement
Averaging static pressure measurement
Ultra low velocity detection
Ideal for installation in existing duct work
Made to measure for ducts from 80 to 450mm Ø
Length manufactured to fit standard duct sizes
Mounting brackets are made to fit round ducts
Easy field positioning and installation
MDF Flowprobes are of anodized aluminium
40 years in service worldwide



MDF Multipoint Duct Flowprobe

The CMR MDF Multipoint Duct Flowprobes have been designed to measure air volume in ventilation ducts. They work in conjunction with the CMR P-Sensor as it provides a linear output signal in m^3/s , m^3/h , l/s or m/s . This means, the combination MDF Flowprobes and P-Sensor provide an accurate and repeatable air volume measurement from 25-100% of the controlled air volume.

The MDF Flowprobe is mounted either horizontally or vertically in the duct. The MDF Flowprobe should be positioned preferably in a straight duct with relatively little air turbulence. The MDF Flowprobe must be fitted so that the averaging holes are facing the air flow to get the best results.

The probe produces a magnified pressure signal which is measured by the P-Sensor. The duct diameter can be entered via the keyboard of the P-Sensor. Low velocities can be measured, as the average measuring points produce a magnified pressure.

In order to convert the velocity pressure into an air volume i.e. m^3/s , m^3/h or l/s the diameter of the duct must be entered into the P-Sensor via the keyboard. The P-Sensor shall calculate the total area in m^2 . After having adjusted the magnification factor, the P-Sensor shall provide an accurate volume output signal for the BMS or Scada system. The P-Sensor has also the facility to linearize the measurements.

MDF Multipoint Duct Flowprobe fitted into a standard duct

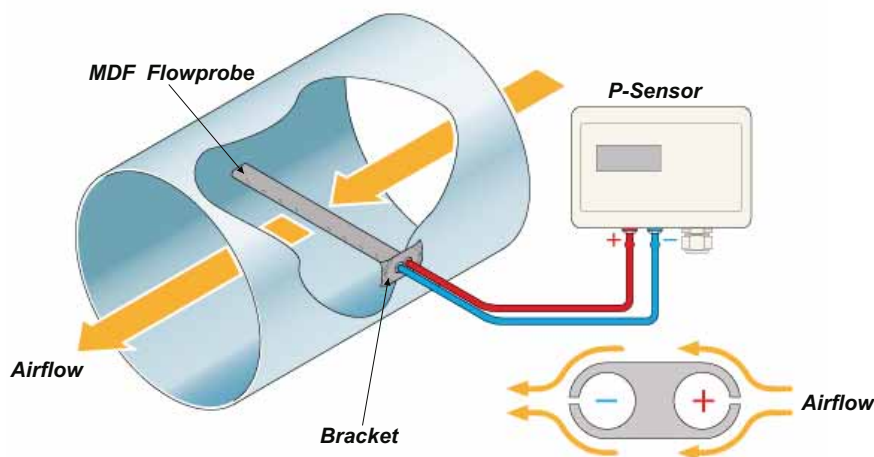

MDF DUCT FLOWPROBE SPECIFICATIONS

Selection of MDF Duct Flowprobes

It is essential to determine the air volume during the design stage. Normally there is a minimum and a maximum volume which has to be measured. The duct area should be calculated so that the velocity is approximately 2 m/s at the minimum volume and preferably 5 m/s at the operating point if possible. If the velocity is more than 5 m/s at the maximum volume then the noise level criteria needs to be considered of the whole installation. The maximum velocity should not exceed 9 m/s as the duct resistance shall increase and the overall energy consumption shall go up.

Installation

The MDF Duct Flowprobes are made to suit standard round duct sizes i.e 80, 100, 125, 140, 150, 160, 180, 200, 224, 250, 280, 300, 315, 355, 400, and 450 mm and are mounted from one side only. See Fig. The Flowprobes are made 5 mm shorter to fit into the duct. It is very important that the length is chosen correctly so that the measurement can be taken across the whole duct. It guarantees that the measurement holes are in the correct duct area to produce the best results.

The probe should be lagged to avoid thermal transfer and condensation on the outside of the duct. The MDF Duct Flowprobe can be installed horizontally or vertically but the tube connections should be on the side or on top to avoid any condensation built up. It works best if it has a reasonable length of duct so that the air flow is laminar when approaching the MDF Flow Probe. If a reasonable length is not available then the magnification factor (mf) can be adjusted on the P-Sensor and it can be linearized over 10 points for unusual measuring positions. This is easily achieved by measuring the air volume with a Pitot Tube at a different location of the duct and adjusting the P-Sensor via the keyboard accordingly.

Accuracy

The MDF Duct Flowprobe can achieve an accuracy of 5% between 25 and 100% of the design volume if it is used with a P-Sensor and the linearization function. If a higher accuracy is to be achieved over the whole range it is better to use multiple MDF Duct Flowprobes and CMR averaging manifolds as indicated in Fig.2 and 3. All fixing components are supplied in the manifold package.

Maintenance

The MDF Duct Flowprobe is maintenance free and when used in conjunction with the P-Sensor there is no air flow going through the Flowprobe and therefore no dust particles can enter the measuring holes as they are pressurised and any particles would be deflected from the Flowprobes. The probes can be retracted for cleaning.

Materials

Flowprobes	- Anodized Aluminium
Bracket	- Stainless Steel 40 x 60mm
Gasket	- Neoprene
Tube Nipples	- Stainless Steel 6.0 mm Ø
Mounting Screws	- Stainless Steel Size 6

Specifications

Recommended minimum air velocity is	2.5 m/s
Recommended operating air velocity is	5.0 m/s
Recommended maximum air velocity is	9.0 m/s

Humidity 10% to 90% non condensing.
 Operating Temperature (dry condition) -20 to 80°C
 Air density factor must be considered

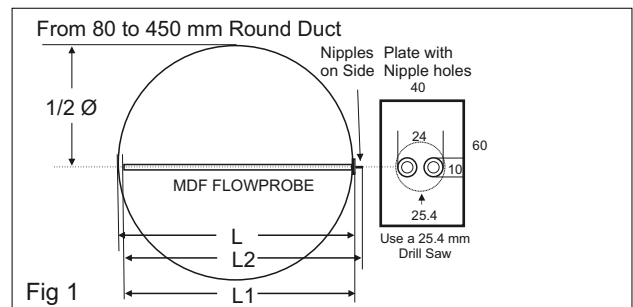

MDF Flowprobe in a round duct single sided

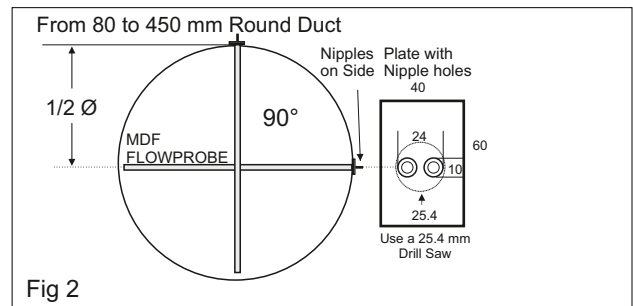

Two MDF Flowprobes in a round duct single sided

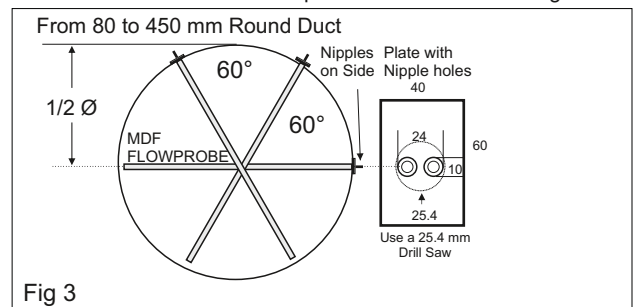

Three MDF Flowprobes in a round duct single sided

MDF FLOWPROBE VELOCITY PRESSURES

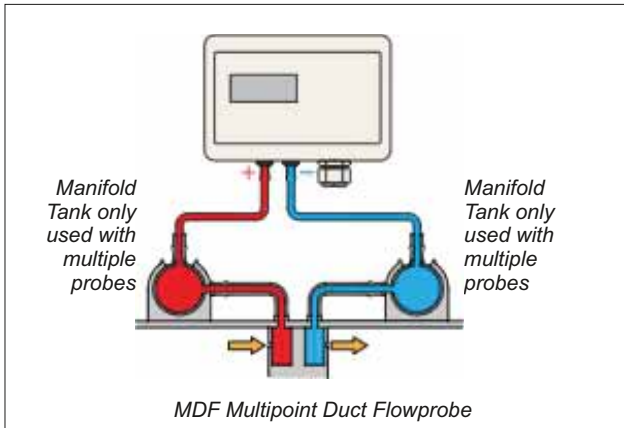

MDF Flowprobe and P-Sensor tube connections

The velocity pressure is measured by the Flowprobes mounted in the duct. The total impact pressure is measured on the positive (+red) and the static pressure is measured on the negative (- blue) Flowprobe. The P-Sensor shall be connected to the corresponding (+) and (-) port using CMR PVC red and blue tube.

If the P-Sensor is ordered with the MDF Flowprobe then it is pre-adjusted at the factory - i.e. duct diameter or width x height, density and MDF Flowprobe Magnification Factor (mf) and the range is in l/s, m³/s, m³/h. It is ready for connection to the control system.

Conversion Table - Velocity in m/s at standard density to Velocity Pressure in Pa

m/s	0.0	0.1	0.2	0.3	0.4	0.5	0.6	0.7	0.8	0.9
0	0.00	0.01	0.02	0.05	0.10	0.15	0.22	0.29	0.38	0.49
1	0.60	0.73	0.86	1.01	1.18	1.35	1.54	1.73	1.94	2.17
2	2.40	2.65	2.90	3.17	3.46	3.75	4.06	4.37	4.70	5.05
3	5.40	5.77	6.14	6.53	6.94	7.35	7.78	8.21	8.66	9.13
4	9.60	10.09	10.58	11.09	11.62	12.15	12.70	13.25	13.82	14.41
5	15.00	15.61	16.22	16.85	17.50	18.15	18.82	19.49	20.18	20.89
6	21.60	22.33	23.06	23.81	24.58	25.35	26.14	26.93	27.74	28.57
7	29.40	30.25	31.10	31.97	32.86	33.75	34.66	35.57	36.50	37.45
8	38.40	39.37	40.34	41.33	42.34	43.35	44.38	45.41	46.46	47.53
9	48.60	49.69	50.78	51.89	53.02	54.15	55.30	56.45	57.62	58.81
10	60.00	61.21	62.43	63.65	64.90	66.15	67.42	68.69	69.98	71.29
11	72.60	73.93	75.26	76.61	77.98	79.35	80.74	82.13	83.54	84.97
12	86.40	87.85	89.30	90.77	92.26	93.75	95.26	96.77	98.30	99.85
13	101.40	102.97	104.54	106.23	107.74	109.35	110.98	112.61	114.26	115.93
14	117.60	119.29	120.98	122.69	124.42	126.15	127.90	129.65	131.42	133.21
15	135.00	136.81	138.62	140.45	142.30	144.15	146.02	147.89	149.78	151.69
16	153.60	155.53	157.46	159.41	161.38	163.35	165.34	167.33	169.34	171.35
17	173.40	175.45	177.50	179.57	181.66	183.75	185.86	187.97	190.10	192.25
18	194.40	196.57	198.74	200.93	203.14	205.35	207.58	209.81	212.06	214.33
19	216.60	218.89	221.18	223.49	225.82	228.15	230.50	232.85	235.22	237.61
20	240.00	242.41	244.82	247.25	249.70	252.15	254.62	257.09	259.58	262.09
21	264.60	267.13	269.66	272.21	274.78	277.35	279.94	282.53	285.14	287.77
22	290.40	293.05	295.70	298.37	301.06	303.75	306.46	309.17	311.90	314.65
23	317.40	320.17	322.94	325.73	328.54	331.35	334.18	337.01	339.86	342.73
24	345.60	348.49	351.38	354.29	357.22	360.15	363.10	366.05	369.02	372.01
25	375.00	378.01	381.02	384.05	387.10	390.15	393.22	396.29	399.38	402.49

To get the range of the P-Sensor use the keyboard and display the range. This is the sensor range in l/s, m³/s or m³/h at 10 V / 20 mA. Enter this range into your control system. No further calculations are necessary. If you want to use the table above use the range of the transmitter in Pa and divide it by the (mf) of the MDF. Look up the velocity above. i.e. 100 Pa / 1.650 (mf) = 60.6 Pa. Look up above ~ 60.6 Pa and read on side and top ~ 10.05 m/s then multiply with the duct area in m² to get m³/s and multiply by 3600 to get m³/h.

If the P-Sensor was ordered separately and it was not factory adjusted then it is quite simple to adjust the parameters on site.

The P-Sensor has a keyboard and the duct inside diameter or height and width of rectangular ducts must be entered. The magnification factor of the MDF Flowprobe must be entered which is normally 1.650.

If the volume indicated on the P-Sensor display is deviating from the actual measurements, then the magnification factor can be adjusted to suit the installation abnormalities via the P-Sensor keyboard.

Adjust the fan to a constant volume – start with 50% of the minimum and maximum operating volume and take a pitot travers reading with an independent instrument. Once the average volume has been established and it is not the same as displayed on the P-Sensor, then adjust the Magnification Factor (mf) until the same display is achieved. For higher accuracy try this at 25%, 75% and 100% volume set point The P-Sensor has parameters to linearize the measurements for more precise applications.

Useful MDF Flowprobe scaling formula:

$$\text{velocity m/s} = \sqrt{\frac{2 \times (\Delta P \text{ in Pa} / \text{mag factor})}{1.2 \text{ Density}}}$$

Example:
 $2 \times (50 \text{ Pa on the MDF} / 1.650 \text{ mf}) = 60.6 / 1.2 = 50.505$
 $\sqrt{50.505} = 7.1066 \text{ m/s}$
 $6.454 \text{ m/s} \times (\text{duct area in m}^2) = \dots \text{ m}^3/\text{s} \times 3600 = \text{m}^3/\text{h}$

MDF FLOWPROBE

ORDER SELECTION

HOW TO ORDER

Call sales at CMR and provide the duct diameter, the minimum and maximum air volume in l/s, m³/s or m³/h and how it is to be mounted in the duct.

You can however configure the part number yourself by using the table below. The selection table has been prepared to make ordering easy. Each column contains a number of different options which can be selected to configure a part number using the mounting type and duct dimensions.

The example part number MDF-24-0450 which is printed above the selection table can be used to try to configure a Part Number to be used in your new application.

The sample shows it is a Multipoint Duct Flowprobe, having a base part Number of MDF - the probe material is Type '24' - the MDF Probe fits a duct diameter of 450mm.

Example Part Number configuration

The code after the [=] sign is used to form the number

MDF-	24-	0450	
Duct Flow	Probe	Duct	
Probe	Type	diameter in mm	
Part No.		'L'	
Base = MDF	Type = 24	L = 080	
	Anodized	L = 100	
	Aluminium	L = 125	
		L = 140	
		L = 150	
		L = 160	
		L = 180	
		L = 200	
		L = 224	
		L = 250	
		L = 280	
		L = 300	
		L = 315	
		L = 355	
		L = 400	
		L = 450	

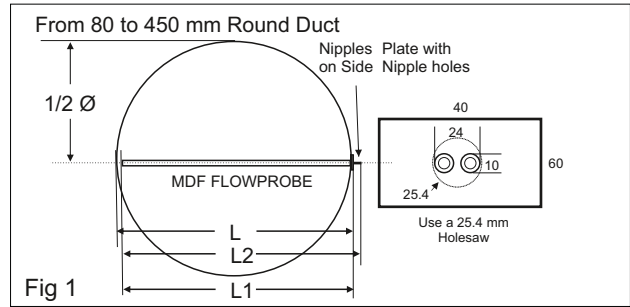

MDF Flowprobe in a round duct single sided

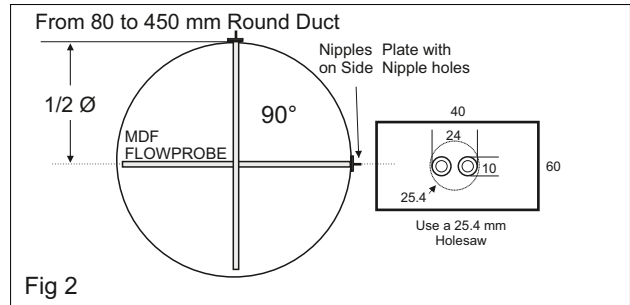

Two MDF Flowprobes in a round duct single sided

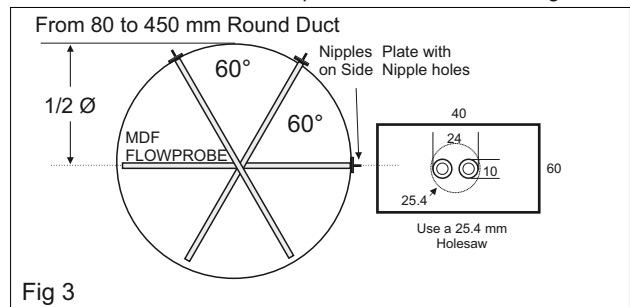

Three MDF Flowprobes in a round duct single sided

EXAMPLE

A duct mounted Multipoint Flowprobe required
The Probe must be anodized Aluminium
The Probe must fit into a round duct with a 450mm Ø diameter.

The part number for this Multipoint Ductprobe is **MDF-24-0450**

Now select the Duct Flowprobe for your installation

MDF-24-

Call CMR for free assistance at any time.

CMR CONTROLS Ltd
Precision Air Pressure and Volume Sensors

22 Repton Court Repton Close
Basildon Essex SS13 1LN GB
web www.cmr-controls.com

Phone +44 (0) 1268 287222
Fax +44 (0) 1268 287099
mail sales@cmr-controls.com

